

## Eye-Gaze Interaction On Computer Screen Evaluation

Wirot Ponglangka \*, Udom Sutakcom\*

\* Department of Electronic, Faculty of Engineering, Rajamangala University of Technology Lanna,  
ChiangRai Campus, ChiangRai,57120 Thailand  
(Tel : +66-5-372-9600; E-mail: w\_ponglangka2@yahoo.com)

**Abstract :** Eye gaze positions evaluation on computer screen uses the human eye as an input device for computer systems is that it gives low resolution. We proposes a method to determine the eye gaze positions on the screen by using two-eye displacements as the information for mapping, and the perspective projection is applied to map the displacements to a position on a computer screen. The experiments were performed on 20 persons and a 17-inch monitor is used with the screen resolution of 1024x768 pixels. Gaze detection error was 3.18 cm (RMS error), with screen is divided into 5x8 and 7x10 positions on a 17-inch monitor. The results showed 100% and 96% correction, respectively.

**Keywords:** Gaze detection, Screen mapping, Perspective and Projection, Displacement

### 1. INTRODUCTION

Once problems of human computer interaction by using eye gaze as an input of computer systems is that it gives low resolution. Therefore the system low resolution is difficulty for user's while they used their eye to control the function on computer screen. The difficulty comes from the method to determine the eye gaze positions of a human when looking on the position on the screen. In addition, it can be applicable to many areas that user's cannot use their hand to communication with computers such as a patient who's cannot use theirs hands to communication with computers.

The method of computers communication starts from the user is gazing to the position on the screen with single camera above the monitor. Then, the eye gaze images were detected for the center of pupil. Gaze detection is to locate the positions on a monitor screen where a user is looking. This process is working before user's applied with many computer interaction systems. These include view in two groups of eye gaze detection that is infrared approach [1-3], and vision-base approach [4-5], regarding to the light sources. The key advantage of the infrared-base approach is that the information is clearer, but it is difficulty to design circuit and control the light sources. These approaches have not selected. On the other hand, by using the images from a single camera above the monitor by vision-base approach is very simple and cheaper more than infrared-approach, but the method to determine the eye gaze position is difficulty. These difficulties have not prevented research in this field, though .However, vision-based approach is divided into two categories. In the first of these is eye gaze tracking system. Matsumoto, O. [6], applied 3D pose of head from stereo camera to detect user's head position at first. After that, the eye gaze was detected. Park and Kim [7], proposed gaze positions detection by compute three-dimensional (3D) positions of facial features from camera calibration and parameter estimation algorithm. The results of these algorithm give eye gaze detection error was  $\pm 5.11$  centimeters (*RMS error*) when the distance between the users and the monitor is 50-70 cm and a 19 inch monitor is used. The screen was divided into 20 positions on 19-inch monitor with resolution of 1280x1024 pixels. These proposed is not sufficient for many applications in computer interaction by eye gaze detection. Therefore, the aim in the second category is eye gaze detection from image while a user's head was fixed. In our work, we implement on a single camera above a monitor when the distance between the user and a monitor is 50-100 cm and a 17-inch monitor is used.

Camera and eye gaze calibration is the first step of our system and two eyes displacements is take to calibration the distance of user's and monitor. The position of eye gaze on a monitor was applied with perspective projection by parameter of camera, monitor and distance of monitor and user's is known. Finally, eye gaze position on the screen was compared with the real positions of a monitor screen and determines the error of eye gaze positions.

### 2. LOCATING FACIAL REGION

In order to detect gaze position on a monitor, we firstly locate a user's face region and facial features in an input image. The facial region is detected by attach the square black label on user's face above the eyebrows between two eye. Then, facial position was detected by using normalize cross-correlation method. The peak of normalize cross-correlation results was the facial feature position as shown in fig 1.

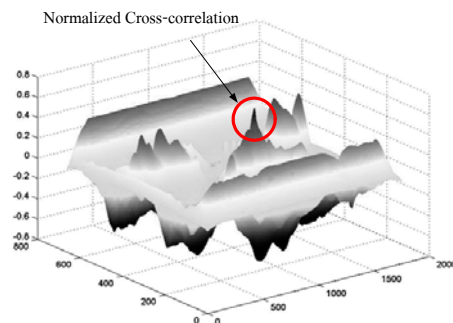
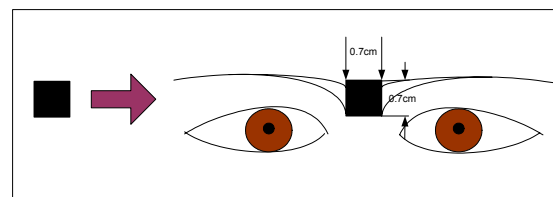

Fig. 1 Facial region detection by Normalize cross-correlation

3. PROPOSAL ALGORITHM

3.1 The process of Eye gaze detection

The eye gaze detection flow is shown in fig. 2. This flow is shown the process of eye gaze detection and translation to the positions on a monitor.

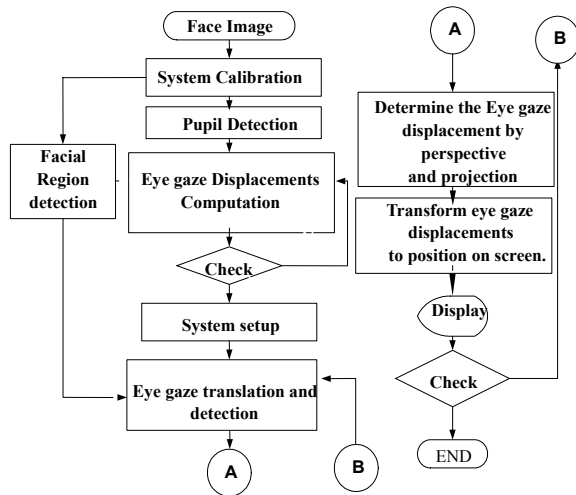

Fig. 2 Eye gaze detection flow

3.2 System calibration

Before determine the eye gaze position on the screen the system was calibrated. There are two step of system calibration. The first is camera calibration as shown in fig. 3 by setting the distance of a scene and camera were 50-100 centimeters and marks the line with known a size of width and height of a scene. Next, setup a camera resolution of 1024x1280 pixels. Then, backward a camera by 1 centimeter from a scene until the distance of camera and a scene is 100 centimeter. After that, measure a line width and height in the images of each distance. A difference of line width and height were recorded in table which is use for initialization the distance of camera and a scene reference with known distance.

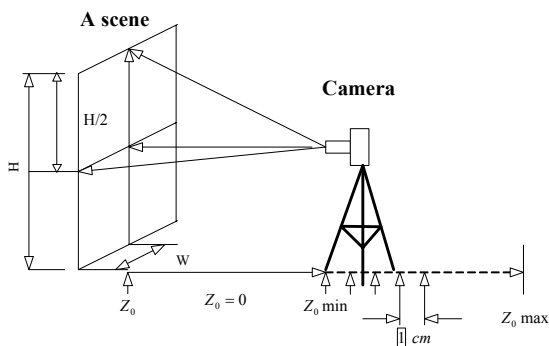

Fig.3 Camera calibration

The second of system calibration as shown in fig.4 by setting the distance between a user's and a monitor start from 50 centimeters and a user's face don't move for a moment.

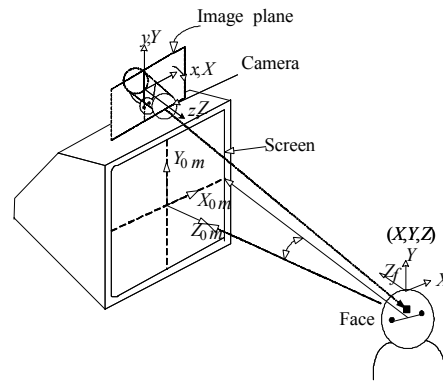

Fig.4. System calibrations

After the system configuration was completed, then we take three steps in order to calibration the system as shown in fig. 5.

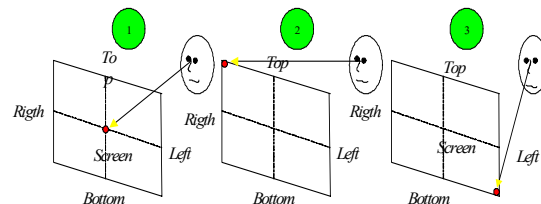

Fig.5 System calibration by eye gazes

In the first step, when a user gazes at three known positions on a monitor with a diameter of 0.5 centimeter. Then, capture a user's face while he looking at a monitor. In the second, detect the pupils of two eyes. The third step, computed two eyes displacements and setting this displacements was the start point of a user and monitor comparisons with displacements of camera calibration at 50 centimeter. The system calibrations always calibrated for every body before use these systems. This system can checkable the distance of user and a monitor automatically after calibration by using two eye displacements.

3.3 Pupil detection

In order to detect pupil or eye gaze center we measuring by hand after we adjust the brightness and contrast of an image and use the function pixval of Matlab 6.1 to measuring the positions of eye gaze as shown in fig.6. The reason of these methods, we satisfy the pupil more precisely before mapping these displacements to a screen.

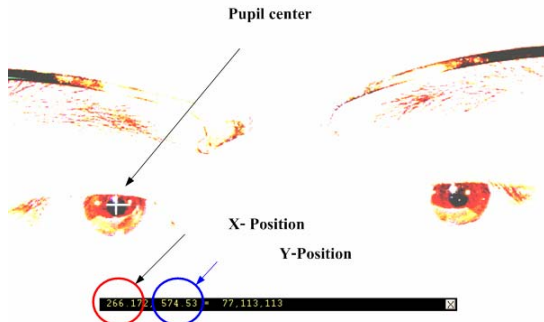

Fig. 6 Pupil detection

3.4 Eye gaze displacements computation

The eye gaze displacements computed from an image while a user is looking at the center of screen as shown in fig. 7 comparisons with other images when user looking at next positions on the screen. These image was separated the distance of right eye ( $\Delta_{XRref}$ ) and left eye ( $\Delta_{XLref}$ ) in horizontal compared with the middle of face marker. Otherwise, the displacements in vertical referred to  $\Delta_{Yref}$  is setting for referenced displacements.

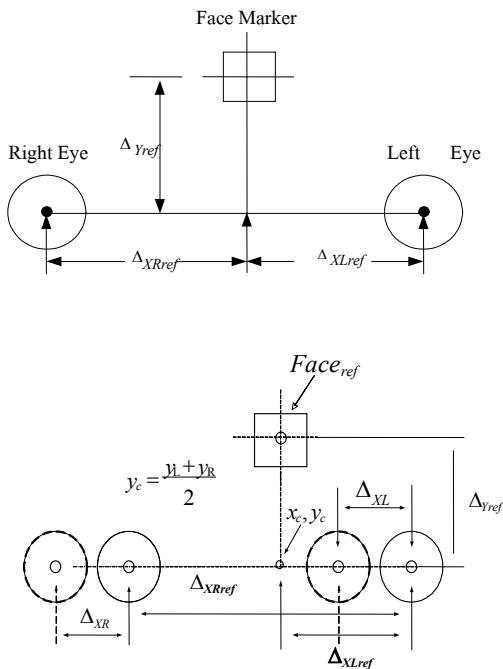

Fig. 7 Eye gaze displacements computation

3.5 Principle of perspective and projection

After we known eye gaze displacements were computed from an images, then we are mapping these displacements to a screen by using the principle of basic camera perspective and projection [8], to compute the positions of the eye on a screen. This principle of perspective and projection is shown in fig.8.

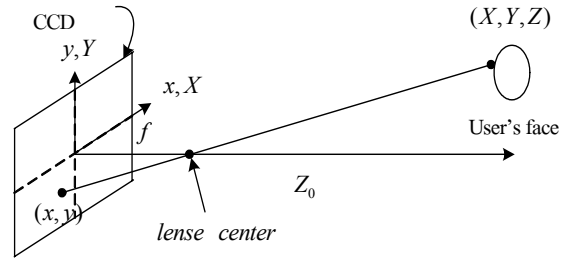

Fig. 8 Basic camera perspective model

The methods in order to transform eye gaze displacements to computer screen have two steps. In first step, CCD size of camera, distance of user's face and monitor are known. Then we transform the real position of user's face projection to CCD. The positions of the eye on CCD were computed by using principle of similar triangle equation (1).

$$x = \frac{X}{f-Z}, y = \frac{Y}{f-Z} \tag{1}$$

In the second step, compute the positions of the eye gaze from CCD of camera by using inverse perspective and projection. For this research we used CCD digital camera were 5.32 x 7.18 mm. The eye gaze images resolution of 1280x960 pixels. The resolutions of image from CCD were computed from equation (2).

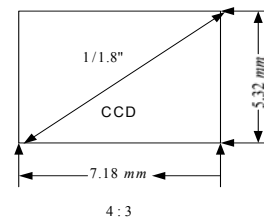

Fig.9 The size of digital camera CCD

$$\begin{aligned} \mu_0 &= H \times 0.0056 \text{ mm} \\ \nu_0 &= V \times 0.0055 \text{ mm} \end{aligned} \tag{2}$$

- where,  $\mu_0$  = The eye positions on horizontal in CCD
- $\nu_0$  = The eye positions on vertical in CCD
- $H$  = The width of image
- $V$  = The height of image

The real positions of the eyes from CCD obtained with equation (3).

$$\begin{aligned} X_0 &= \frac{H_0}{f}(f - Z_0) \\ Y_0 &= \frac{V_0}{f}(f - Z_0) \end{aligned} \quad (3)$$

### 3.6 Eye gaze displacements uses to mapping to a screen

After eye gaze displacement was computed, in order to mapping a user's eye gaze displacements to a screen, the eyes displacements should be the same unit as in centimeter form. From fig. 10, we computed positions of eye gaze on the screen by using the principle of similar triangle equation (3).

- Where,
- $\Delta_{XL}, \Delta_{XR}$  = Eye gaze displacements
  - $P_1 - P_3$  = Test point on a screen
  - $B$  = The midpoint of the eyes
  - $S_C$  = A Half of Screen
  - $S_L, S_R$  = Distance of the eyes to a reference point on the user's face.
  - $S_T$  = An addition of a half of a screen and distance of the eyes with the reference point.

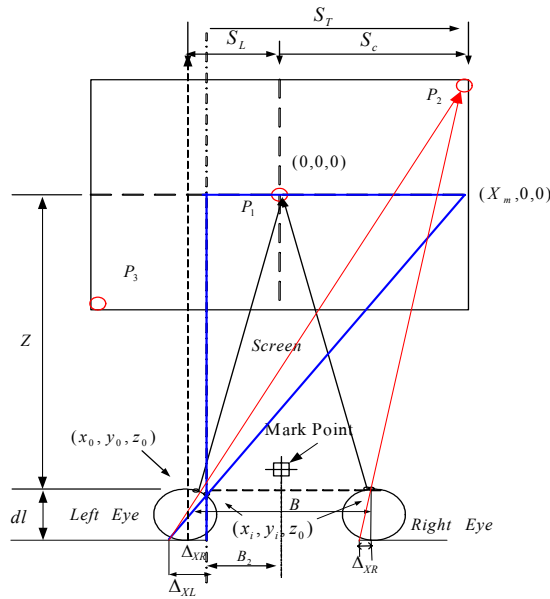

Fig.10 Geometry of user's eye while looking at a screen.

The position of eye gaze was computed from the method of perspective and projection and principle of similarly triangle referred to equation (4) for the right hand side of user.

$$S_C = S_T - (S_L - \Delta_{XR}) \quad (4)$$

On the other hand, when a user gazes to the left hand side of a monitor, we computed the positions of the eye gaze on a screen by equation (5).

$$\begin{aligned} S_T &= -S_C + (S_R - \Delta_{XL}) \\ S_T &= \frac{Z \times \Delta_{XL}}{dl} \\ S_C &= -S_T + (S_R - \Delta_{XL}) \end{aligned} \quad (5)$$

## 5. AN EXPERIMENTS

### 5.1 Experiment conditions

In order to have an experiment, this system used 17-inch of a screen and divided into 10x10 positions. The positions on screen are 100 points. Screen resolutions of 1024x768 pixels. Resolutions of an image were 1280x960 pixels. A CCD resolution was 0.005609375 mm/pixel. A focal length of camera was 39.117 mm. The system configuration is shown in fig. 11.



Fig.11 The system configuration

### 5.2 Eye gaze computation and evaluation on a screen

The experiments results intend on an accuracy of the proposed gaze detection algorithm. The gaze detection error (RMS error) is comparison between the real positions and the computation from experiments. Here, we have an experimented in one case by the facial of user is not move or rotation. For this case, we used 20 users in experiments and gazes at 100 positions on 17-inch of monitor (1024x768 pixel resolutions).The Experimental results show that the gaze detection error is  $\pm 3.18 \text{ cm}$  (32 pixel/cm). From these results, the screen was dividing into 7x10 positions maximum on a 17-inch monitor with the screen resolution of 1024x768 pixels. The results showed 96% correction. On the other hand, we have experiment with 4 user's gazes at 5x8 positions on the screen. The results showed 100% correction.

6. CONCLUSIONS

This paper describes a method for detection the gaze positions and evaluation on a monitor by a single camera. In order to detect the gaze position, we locate two-eye center by manual in 2D camera of an images and estimate the initial feature by camera calibration. When the center of two-eye is determined, the distances between the center of the eyes and the reference point on the user face are calculated. These distances are used in computing the displacement. Finally, given that the distance between the user's face and camera is known, the perspective projection is applied to map the displacement to a position on a screen. A camera calibration is required for setting the distance between the user's face and the camera. To evaluate the method, the experiments were performed on 20 persons. The distance between the user's face and the camera was at 60 cm, and the screen was divided into 10x10 positions on a 17-inch monitor with the screen resolution of 1024 x 768 pixels. The result resolution was  $\pm 3.18$  cm, which can be translated into to menu of 5 x 8 positions on a 17-inch monitor. Finally, the experiments were carried out with the menu of 5x8 and 7x10 positions on 4 of the 20 persons. The results showed 100 percent and 96 percent correction. These researches require more technique to detection eye gaze center and improving to applications by using tracking.

REFERENCES

- [1] Hutchinson, T.E., White, K.P., Martin, W.N., Reichert, K.C. and Frey, L.A., (1989). "Human-Computer Interaction Using Eye-Gaze input", IEEE Transaction on Systems, Man, and Cybernetics, Vol. 19, No. 6, pp.1527-1534.
- [2] Ebisawa, Y. (1998). "Improved Video-Base Eye-Gaze Detection Method". IEEE Trans on Ins., and Measurement. Vol. 47, no.4, pp.948-955.
- [3] Ebisawa, Y. (1991). "Non - Invasive Eye-Gaze Position Detecting Method Used On Man Machine" IEEE Trans. On Medical and Prosthetic, pp 374-380.
- [4] Colombo, C. Andronico, S. and Dario, P. (1995). "Prototype of A vision-based gaze-driven man-machine interface", IEEE, pp.188-192.
- [5] Sugioka, A. Ebisawa, Y. and Masao, O. (1996). "Non contact Video-Based Eye-Gaze Detection Method Allowing Large Head Displacements", 18<sup>th</sup> Annual International conference of IEEE Engineering In Med, and Bio, pp.526-528.
- [6] Matsumoto, O. et.at, (2000). "Behavior Recognition Based On Head Pose and Gaze Direction Measurement", Proceeding of IEEE RSJ, International Conference on Intelligent Robot and systems, pp 2127-2132.
- [7] Park, K.R., Lee, J.J. and Kim, J., (2002). "Gaze position detection by computing The three Dimensional facial position and motions", Journal of The Pattern Recognition, Vol. 35, No. 11, pp. 2559-2569.
- [8] Gonzalez, R.C. and Wood, R.E.,(1993), Digital Image Processing, Addison - Wesley Publishing Company, New York, pp. 51-68.

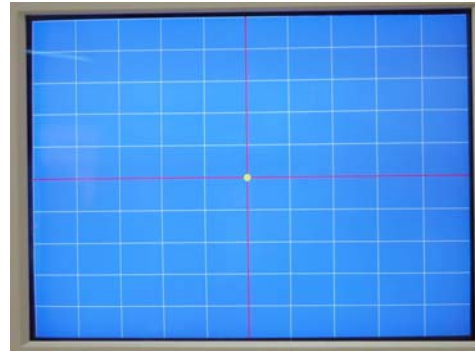

Fig. 12 Test point on a screen



Fig. 13 System configuration setup

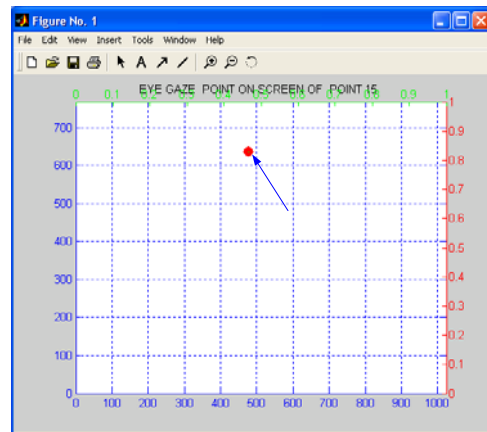

Fig. 14 The results of eye gaze position on a screen